

LEWIS

TOWER SYSTEMS



Industrial Ladder Tower

Double Width Tower Assembly Guide

Product Information and Assembly Guide



Double Width Tower Assembly Guide

This document will provide all users of Lewis Access Towers with a complete guide to the erection of the Lewis SW (Double Width) Aluminium Tower, employing the 3T (Through the Trap) method.

The user should read the entire contents of this document before commencing assembly and pay particular attention to all of the safety instructions. If the equipment is passed onto another party a copy of these instructions should accompany the handover.

Two persons are necessary to carry out the erection of the equipment detailed in this document. It is strongly recommended that the following items of personal protection equipment be worn at all times: safety boots (EN345 or BS1870 / 4972); safety helmet (EN397 or BS5240); gloves. The SWL (Safe Working Load) for each platform is 275kg, evenly dispersed.

The Lewis Tower is a Class 3 Industrial Tower System

The tower should be manoeuvred into position by hand by pushing it from the base frame. Never attempt to use any mechanical equipment (i.e. a forklift etc.) to move the tower.

If it is necessary to lift individual components whilst assembling the tower, a dependable knot should fasten each item.

Be aware of overhead obstructions – pay particular attention to any live electrical cables. Ensure that no persons, materials or tools are on the tower when it is being moved.

Additional care should be taken when moving the tower on uneven or inclining ground. The use of the castor locks should be deployed when the tower is in position. When moving the tower the stabilisers should only be lifted 35mm from ground level.

Towers under 4m in height are the only towers that should be moved.

- Check all components (see component list) are available and in usable condition.
- Damaged or incorrect components should not be used.

Working on the Tower - The Beaufort Windscale

Scale 4. 13 - 18 mph **OK TO WORK ON TOWER**

Moderate Breeze: Raises dust, loose paper; moves small branches

Scale 5. 19 - 24 mph **STOP WORKING ON TOWER**

Fresh Breeze: Small trees in leaf begin to sway; white crested wavelets form on inland waters

Scale 6. 25 - 31 mph **DISMANTLE TOWER**

Strong Breeze: Large branches in motion; umbrellas used with difficulty; telephone wires “whistle”.

Be aware that wind conditions are a very important consideration when using a tower. Attention must be paid to individual situations where wind conditions can increase - i.e. when working between buildings, or close to the corner of a building and at open ends.

Never use tarpaulins or similar covers without seeking the correct advice.

Ballast for Towers up to 12.2m in height, ballast is not necessary

DOUBLE WIDTH INTERNAL AND EXTERNAL USE

Working Height in (m)	3.2	3.7	4.2	4.7	5.2	5.7	5.2	6.7	7.2	7.7	8.2	8.7
Platform Height in (m)	1.2	1.7	2.2	2.7	3.2	3.7	4.2	4.7	5.2	5.7	6.2	6.7
Castor	4	4	4	4	4	4	4	4	4	4	4	4
Adjustable Leg	4	4	4	4	4	4	4	4	4	4	4	4
2 Rung Ladder Frame	0	0	1	0	0	1	1	0	0	1	1	0
2 Rung End Frame	0	0	1	0	0	1	1	0	0	1	1	0
3 Rung Ladder Frame	0	1	0	1	0	1	0	1	0	1	0	1
3 Rung End Frame	0	1	0	1	0	1	0	1	0	1	0	1
4 Rung Ladder Frame	1	0	1	1	2	1	2	2	3	2	3	3
4 Rung End Frame	1	0	1	1	2	1	2	2	3	2	3	3
Trapdoor Platform	1	1	1	1	2	2	2	2	2	2	2	3
Fixed Platform	1	1	1	1	1	1	1	1	1	1	1	1
Horizontal Brace	6	6	6	6	10	10	10	10	10	10	10	14
Diagonal Brace	2	2	3	4	5	6	7	8	9	10	11	12
Toe Board Set	1	1	1	1	1	1	1	1	1	1	1	1
Standard Stabilisers	0	0	0	4	4	4	4	4	4	4	0	
Jumbo Stabilisers	0	0	0	0	0	0	0	0	0	0	4	4
Total Self Weight of Tower (Kg) - 1.8m	92	97	105	128	159	161	174	181	189	201	207	237
Total Self Weight of Tower (Kg) - 2.5m	105	110	119	142	179	190	195	203	211	224	230	266

Working Height in (m)	9.2	9.7	10.2	10.7	11.2	11.7	12.2	12.7	13.2	13.7	14.2
Platform Height in (m)	7.2	7.7	8.2	8.7	9.2	9.7	10.2	10.7	11.2	11.7	12.2
Castor	4	4	4	4	4	4	4	4	4	4	4
Adjustable Leg	4	4	4	4	4	4	4	4	4	4	4
2 Rung Ladder Frame	0	1	1	0	0	1	1	0	0	1	1
2 Rung End Frame	0	1	1	0	0	1	1	0	0	1	1
3 Rung Ladder Frame	0	1	0	1	0	1	0	1	0	1	0
3 Rung End Frame	0	1	0	1	0	1	0	1	0	1	0
4 Rung Ladder Frame	4	3	4	4	5	4	5	5	6	5	6
4 Rung End Frame	4	3	4	4	5	4	5	5	6	5	6
Trapdoor Platform	3	3	3	3	3	3	3	4	4	4	4
Fixed Platform	1	1	1	1	1	1	1	1	1	1	1
Horizontal Brace	14	14	14	14	14	14	14	14	18	18	18
Diagonal Brace	13	14	15	16	17	18	19	20	21	22	23
Toe Board Set	1	1	1	1	1	1	1	1	1	1	1
Standard Stabilisers	0	0	0	0	0	0	0	0	0	0	0
Jumbo Stabilisers	4	4	4	4	4	4	4	4	4	4	4
Total Self Weight of Tower (Kg) - 1.8m	250	260	264	290	298	308	313	344	351	359	366
Total Self Weight of Tower (Kg) - 2.5m	279	290	295	317	335	346	351	388	396	404	412

Double Width Tower Assembly Instructions

1.1 Prepare ladder frame for assembly



1.2 Insert a leg and castor assembly into the bottom end of a ladder frame



1.3 Prepare span frame for assembly



1.4 Insert a leg and castor assembly into the bottom end of a span frame.



1.5 Clip horizontal brace onto span frame. Connect the brace directly above the casting at the first horizontal rung position. And then attach to ladder frame.



1.6 Clip the second brace in the same position. Make sure the base is level using a spirit level. If alterations are required do so by adjusting legs.



1.7 Make sure that the trigger is facing to outside of frame.

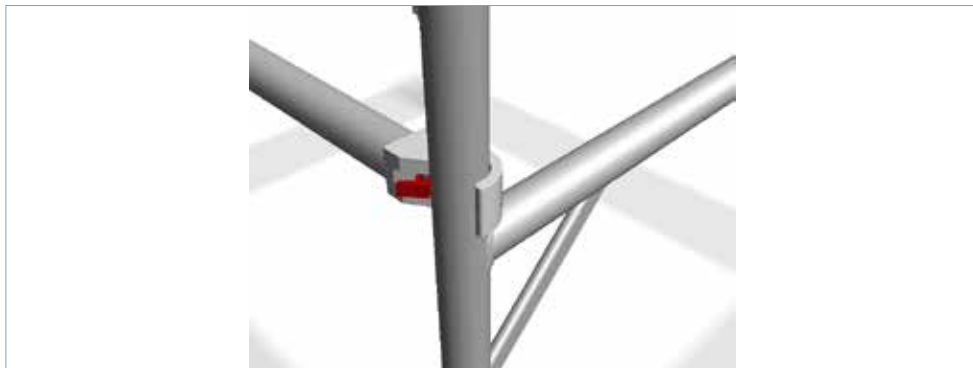

1.8 Insert 4 rung frame.



1.9 Clip diagonal braces onto the lowest rungs.



1.10 Insert 4 rung frame.



1.11 Clip diagonal braces onto the lowest rungs.



1.12 When fitting the stabilisers, position each one in opposing directions. Adjust all four castors to ensure the tower is square and level. Use a spirit level.



1.13



1.14



1.15



1.16 Stabilisers must be in opposing directions to ensure full stability of tower.



1.17 Ensure spring clips are located in the locked position.



1.18 Attach trap door platform on the 4th rung, approx 2.2m above ground level.



1.19 Align platform alongside the ladder.



1.20



1.21 Climb ladder and open trapdoor. Sit with feet through the platform with both feet on the ladder. Fit four guardrail braces on the 4th & 6th rungs directly above the sides of the platform.



1.22



1.23



1.24



1.25



1.26 Clip diagonal braces into position.



1.27 Clip diagonal braces into position.

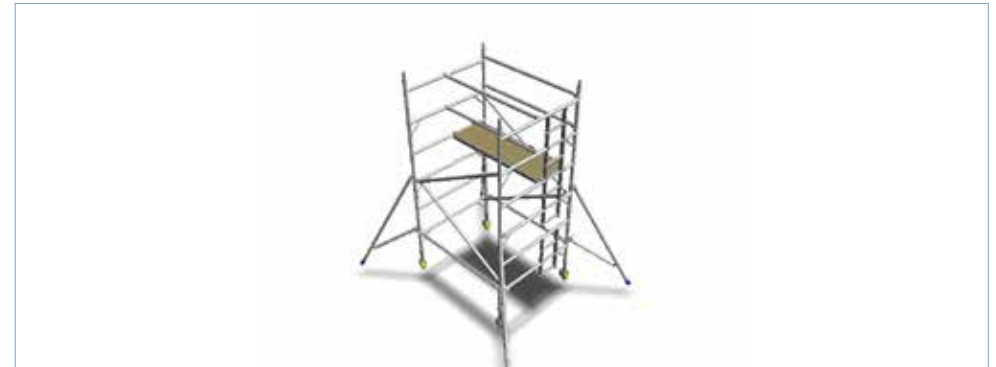

1.28 Stand on platform and ensure the guardrails are securely in place at the opposite end of the tower.



1.29 AT THIS STAGE A 2.2m TOWER HAS BEEN FULLY ERECTED.



1.30 Build next lift of four rung frames.

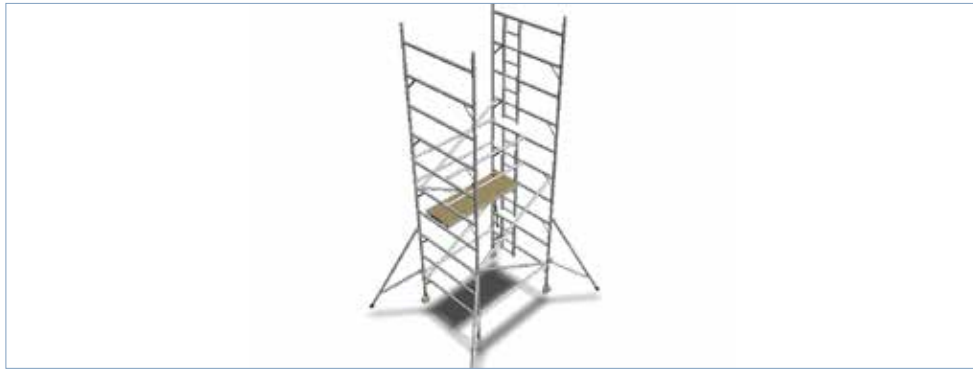

1.31 Clip diagonals into position.



1.32

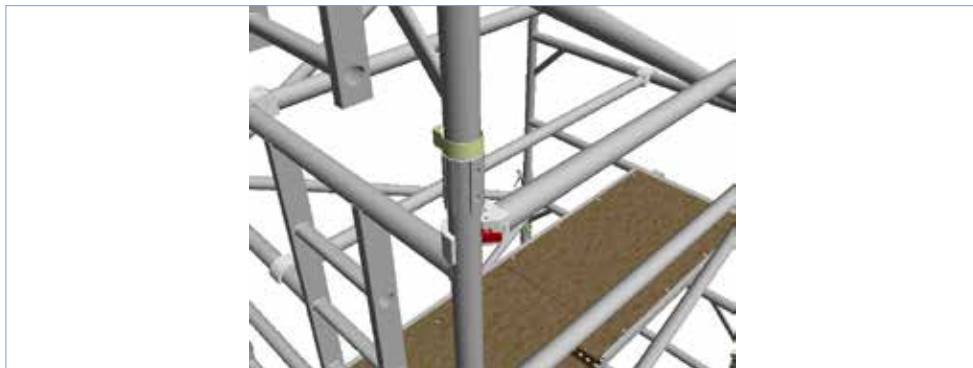

1.33

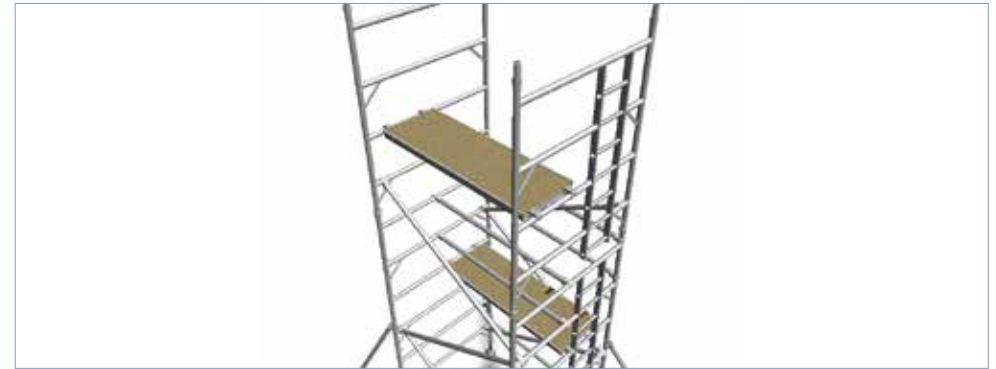

1.34 Ensure spring clips are located in the locked position.

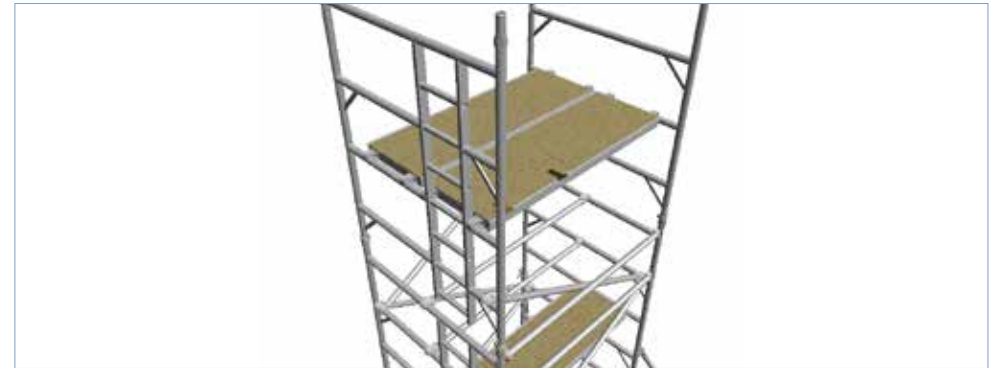

1.35



1.36 Climb ladder and open trapdoor. Sit with feet through the platform with both feet on the ladder. Fit four guardrail braces on the 9th & 10th rungs directly above the sides of the platform.



1.37



1.38



1.39



1.40



1.41 Clip diagonal braces into position.



1.42 Clip diagonal braces into position.



1.43 Stand on platform and ensure that guardrails are securely in place at the opposite ends of the tower.



1.44 Fit toeboard set securely.



1.45 AT THIS STAGE A 4.2m TOWER HAS NOW BEEN FULLY ERECTED.



Dismantling

To dismantle the LEWIS Double Width tower, first remove the toeboard set and send safely down the tower. Remove the furthest of the four guardrails and diagonal brace. Go directly to the trapdoor platform next to the ladder frame to remove the braces completely. To fully dismantle the tower reverse the erection procedure detailed in this guide above.

Stability

Towers left unattended or unused for extended periods in exposed situations should be dismantled. Horizontal forces i.e. pressure exerted when drilling into a building face can yield instability in the tower. The tower must not be used to gain access to a neighbouring structure. Tower are not intended to be suspended.

Transport and Storage

Components should be transported and stored vertically. Damaged items must be repaired by a competent person. Contact your supplier for advice.



Further Information

For further information and support please contact us on:

0800 043 2222

info@scaffold-tower.co.uk

www.lewisaccess.co.uk

Unit 1 Bellingham Trading Estate
Franthorne Way
London
SE6 3BX

