

Double Width Tower
3.2m Long x 1.45m wide

Working Height
3.2m

Platform Height
1.2m

Tower Components

Item	Description	Quantity
1	150mm Locking Castor	4
2	Adjustable Leg 500mm	4
3	4 rung 1m Frame	0
4	6 rung 1.5m Frame	0
5	8 rung 2m Frame	2
6	3.2m Trapdoor Platforms	1
7	3.2m Fixed Platforms	1
8	3.2m Horizontal Brace	6
9	3.5m Diagonal Brace	2
10	Complete Toe Board Set	1
11	Standard Stabilisers	0
12	Jumbo Stabilisers	0
13	Instruction Manual & BSEN1004 certificate of conformity	1

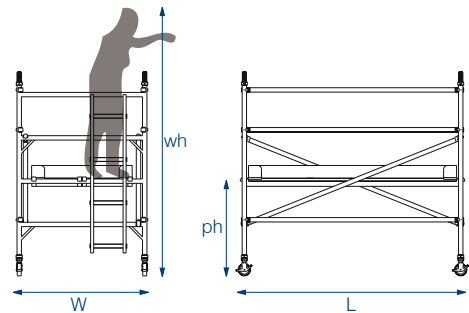

Technical Information

Base Dimensions:	(L)3.2m X (W)1.45m
Maximum Platform Height (ph):	1.2m
Maximum Working Height (wh):	3.2m
Maximum Working Load Per Platform:	275kg
Maximum Working Load Per Tower: (including tower weight)	950kg
Weight:	

Double Width Tower
3.2m Long x 1.45m wide

Working Height
3.7m

Platform Height
1.7m

Tower Components

Item	Description	Quantity
1	150mm Locking Castor	4
2	Adjustable Leg 500mm	4
3	4 rung 1m Frame	2
4	6 rung 1.5m Frame	2
5	8 rung 2m Frame	0
6	3.2m Trapdoor Platforms	1
7	3.2m Fixed Platforms	1
8	3.2m Horizontal Brace	6
9	3.5m Diagonal Brace	3
10	Complete Toe Board Set	1
11	Standard Stabilisers	0
12	Jumbo Stabilisers	0
13	Instruction Manual & BSEN1004 certificate of conformity	1

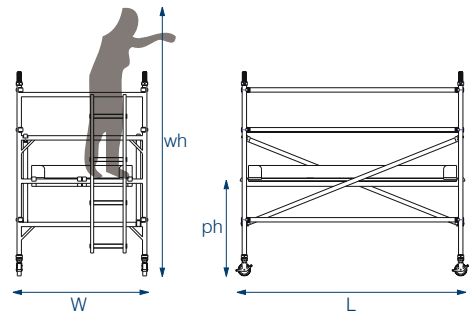

Technical Information

Base Dimensions:	(L)3.2m X (W)1.45m
Maximum Platform Height (ph):	1.7m
Maximum Working Height (wh):	3.7m
Maximum Working Load Per Platform:	275kg
Maximum Working Load Per Tower: (including tower weight)	950kg
Weight:	

Double Width Tower
3.2m Long x 1.45m wide

Working Height
4.2m

Platform Height
2.2m

Tower Components

Item	Description	Quantity
1	150mm Locking Castor	4
2	Adjustable Leg 500mm	4
3	4 rung 1m Frame	2
4	6 rung 1.5m Frame	0
5	8 rung 2m Frame	2
6	3.2m Trapdoor Platforms	1
7	3.2m Fixed Platforms	1
8	3.2m Horizontal Brace	6
9	3.5m Diagonal Brace	3
10	Complete Toe Board Set	1
11	Standard Stabilisers	0
12	Jumbo Stabilisers	0
13	Instruction Manual & BSEN1004 certificate of conformity	1

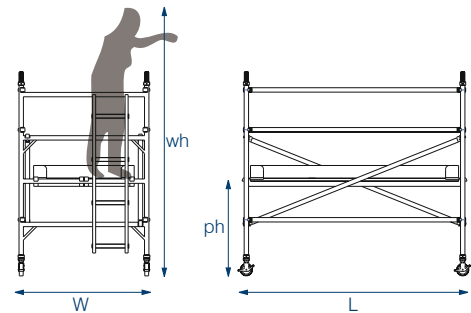
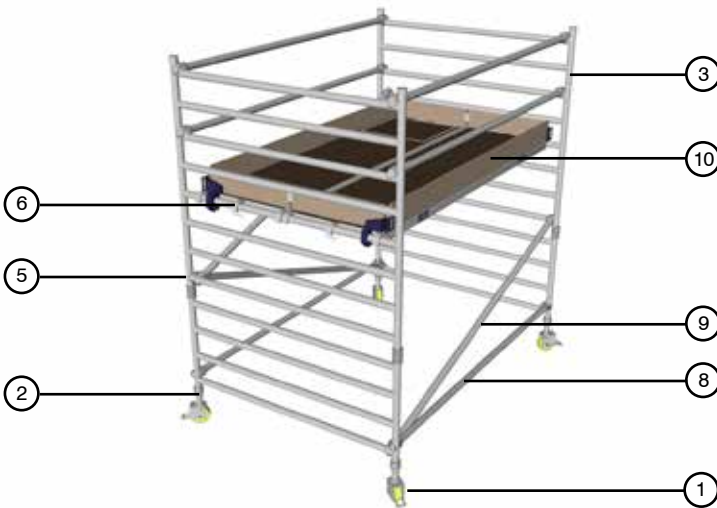

Technical Information

Base Dimensions:	(L)3.2m X (W)1.45m
Maximum Platform Height (ph):	2.2m
Maximum Working Height (wh):	4.2m
Maximum Working Load Per Platform:	275kg
Maximum Working Load Per Tower: (including tower weight)	950kg
Weight:	

Double Width Tower
3.2m Long x 1.45m wide

Working Height
4.7m

Platform Height
2.7m

Tower Components

Item	Description	Quantity
1	150mm Locking Castor	4
2	Adjustable Leg 500mm	4
3	4 rung 1m Frame	0
4	6 rung 1.5m Frame	2
5	8 rung 2m Frame	2
6	3.2m Trapdoor Platforms	1
7	3.2m Fixed Platforms	1
8	3.2m Horizontal Brace	6
9	3.5m Diagonal Brace	4
10	Complete Toe Board Set	1
11	Standard Stabilisers	4
12	Jumbo Stabilisers	0
13	Instruction Manual & BSEN1004 certificate of conformity	1

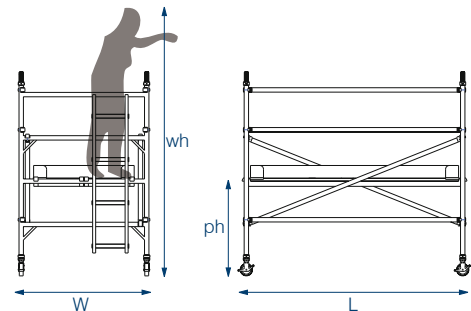

Technical Information

Base Dimensions:	(L)3.2m X (W)1.45m
Maximum Platform Height (ph):	2.7m
Maximum Working Height (wh):	4.7m
Maximum Working Load Per Platform:	275kg
Maximum Working Load Per Tower: (including tower weight)	950kg
Weight:	

Double Width Tower
3.2m Long x 1.45m wide

Working Height
5.2m

Platform Height
3.2m

Tower Components

Item	Description	Quantity
1	150mm Locking Castor	4
2	Adjustable Leg 500mm	4
3	4 rung 1m Frame	0
4	6 rung 1.5m Frame	0
5	8 rung 2m Frame	4
6	3.2m Trapdoor Platforms	2
7	3.2m Fixed Platforms	1
8	3.2m Horizontal Brace	10
9	3.5m Diagonal Brace	5
10	Complete Toe Board Set	1
11	Standard Stabilisers	4
12	Jumbo Stabilisers	0
13	Instruction Manual & BSEN1004 certificate of conformity	1

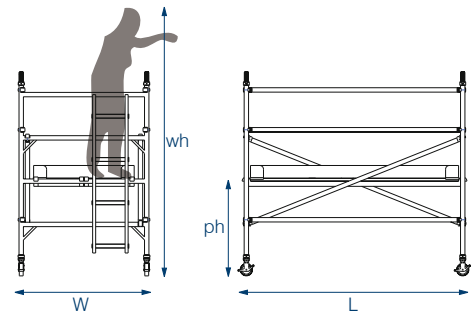
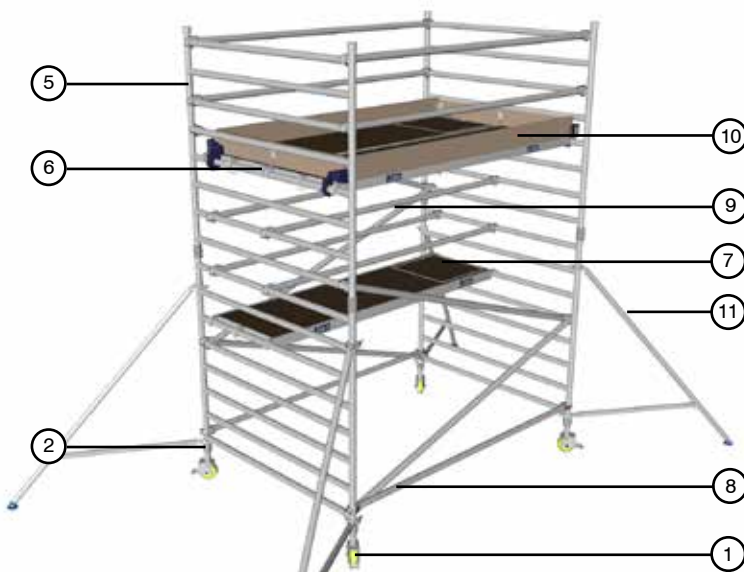

Technical Information

Base Dimensions:	(L)3.2m X (W)1.45m
Maximum Platform Height (ph):	3.2m
Maximum Working Height (wh):	5.2m
Maximum Working Load Per Platform:	275kg
Maximum Working Load Per Tower: (including tower weight)	950kg
Weight:	

Double Width Tower
3.2m Long x 1.45m wide

Working Height
5.7m

Platform Height
3.7m

Tower Components

Item	Description	Quantity
1	150mm Locking Castor	4
2	Adjustable Leg 500mm	4
3	4 rung 1m Frame	2
4	6 rung 1.5m Frame	2
5	8 rung 2m Frame	2
6	3.2m Trapdoor Platforms	2
7	3.2m Fixed Platforms	1
8	3.2m Horizontal Brace	10
9	3.5m Diagonal Brace	6
10	Complete Toe Board Set	1
11	Standard Stabilisers	4
12	Jumbo Stabilisers	0
13	Instruction Manual & BSEN1004 certificate of conformity	1

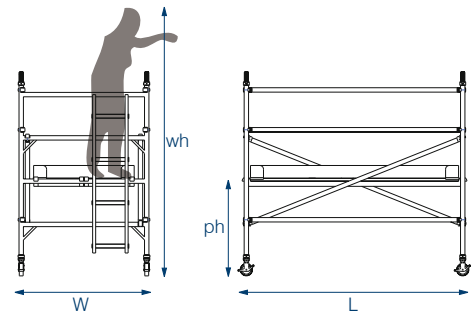
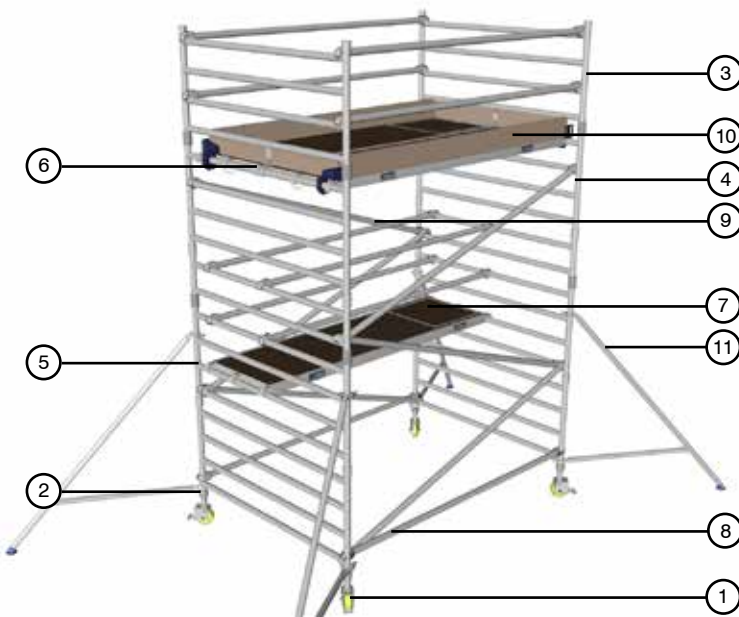

Technical Information

Base Dimensions:	(L)3.2m X (W)1.45m
Maximum Platform Height (ph):	3.7m
Maximum Working Height (wh):	5.7m
Maximum Working Load Per Platform:	275kg
Maximum Working Load Per Tower: (including tower weight)	950kg
Weight:	

Double Width Tower
3.2m Long x 1.45m wide

Working Height
6.2m

Platform Height
4.2m

Tower Components

Item	Description	Quantity
1	150mm Locking Castor	4
2	Adjustable Leg 500mm	4
3	4 rung 1m Frame	2
4	6 rung 1.5m Frame	0
5	8 rung 2m Frame	4
6	3.2m Trapdoor Platforms	2
7	3.2m Fixed Platforms	1
8	3.2m Horizontal Brace	10
9	3.5m Diagonal Brace	7
10	Complete Toe Board Set	1
11	Standard Stabilisers	4
12	Jumbo Stabilisers	0
13	Instruction Manual & BSEN1004 certificate of conformity	1

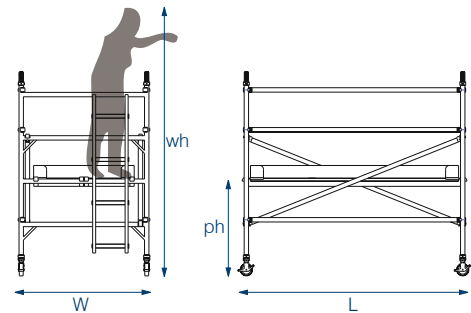
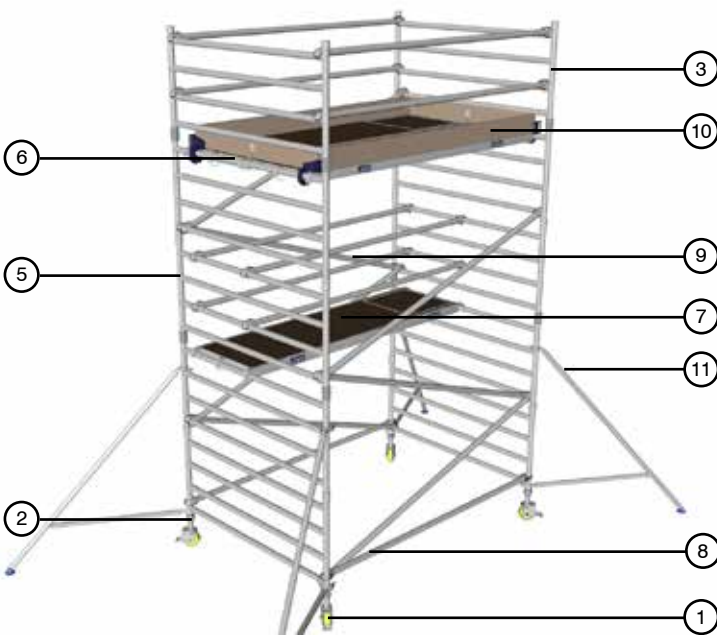

Technical Information

Base Dimensions:	(L)3.2m X (W)1.45m
Maximum Platform Height (ph):	4.2m
Maximum Working Height (wh):	6.2m
Maximum Working Load Per Platform:	275kg
Maximum Working Load Per Tower: (including tower weight)	950kg
Weight:	

Double Width Tower
3.2m Long x 1.45m wide

Working Height
6.7m

Platform Height
4.7m

Tower Components

Item	Description	Quantity
1	150mm Locking Castor	4
2	Adjustable Leg 500mm	4
3	4 rung 1m Frame	0
4	6 rung 1.5m Frame	2
5	8 rung 2m Frame	4
6	3.2m Trapdoor Platforms	2
7	3.2m Fixed Platforms	1
8	3.2m Horizontal Brace	10
9	3.5m Diagonal Brace	8
10	Complete Toe Board Set	1
11	Standard Stabilisers	4
12	Jumbo Stabilisers	0
13	Instruction Manual & BSEN1004 certificate of conformity	1

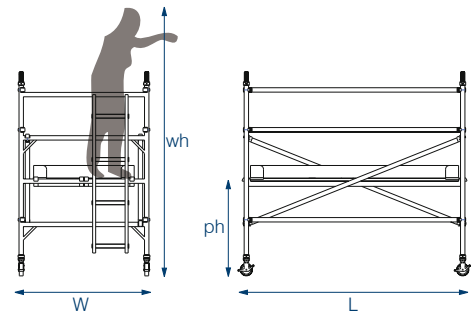
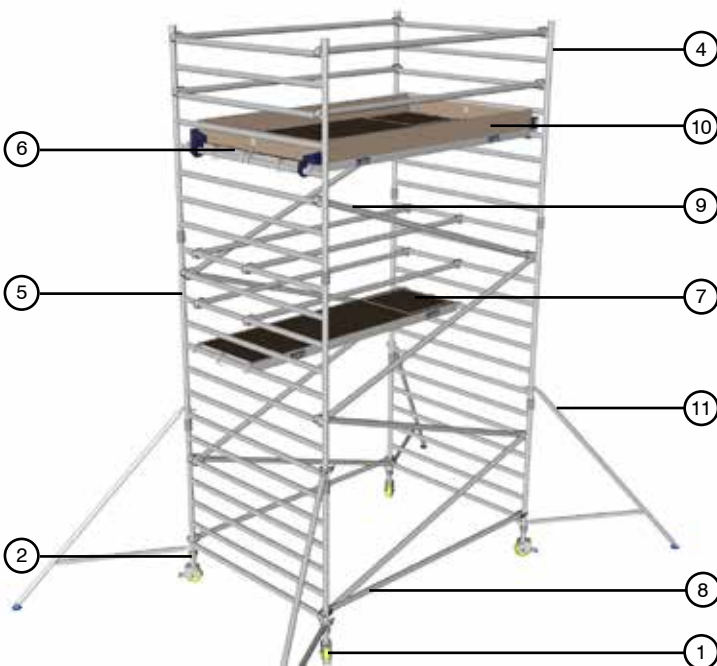

Technical Information

Base Dimensions:	(L)3.2m X (W)1.45m
Maximum Platform Height (ph):	4.7m
Maximum Working Height (wh):	6.7m
Maximum Working Load Per Platform:	275kg
Maximum Working Load Per Tower:	950kg
(including tower weight)	
Weight:	

Double Width Tower
3.2m Long x 1.45m wide

Working Height
7.2m

Platform Height
5.2m

Tower Components

Item	Description	Quantity
1	150mm Locking Castor	4
2	Adjustable Leg 500mm	4
3	4 rung 1m Frame	0
4	6 rung 1.5m Frame	0
5	8 rung 2m Frame	6
6	3.2m Trapdoor Platforms	2
7	3.2m Fixed Platforms	1
8	3.2m Horizontal Brace	10
9	3.5m Diagonal Brace	9
10	Complete Toe Board Set	1
11	Standard Stabilisers	4
12	Jumbo Stabilisers	0
13	Instruction Manual & BSEN1004 certificate of conformity	1

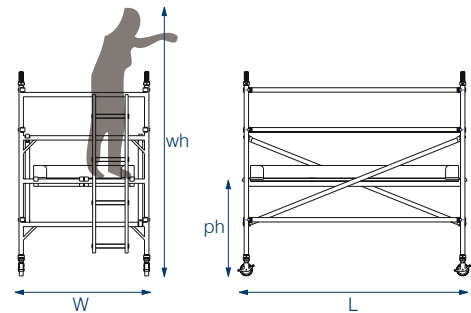
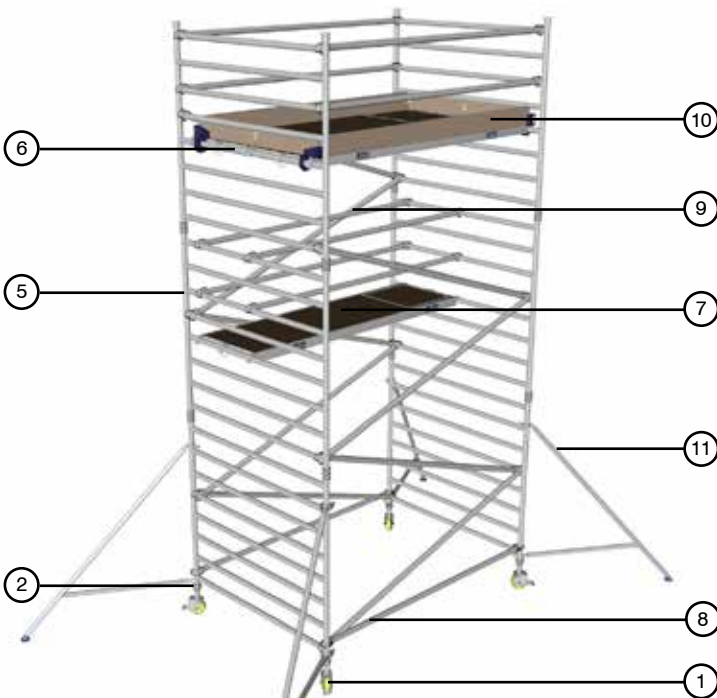

Technical Information

Base Dimensions:	(L)3.2m X (W)1.45m
Maximum Platform Height (ph):	5.2m
Maximum Working Height (wh):	7.2m
Maximum Working Load Per Platform:	275kg
Maximum Working Load Per Tower: (including tower weight)	950kg
Weight:	

Double Width Tower
3.2m Long x 1.45m wide

Working Height
7.7m

Platform Height
5.7m

Tower Components

Item	Description	Quantity
1	150mm Locking Castor	4
2	Adjustable Leg 500mm	4
3	4 rung 1m Frame	2
4	6 rung 1.5m Frame	2
5	8 rung 2m Frame	4
6	3.2m Trapdoor Platforms	2
7	3.2m Fixed Platforms	1
8	3.2m Horizontal Brace	10
9	3.5m Diagonal Brace	10
10	Complete Toe Board Set	1
11	Standard Stabilisers	4
12	Jumbo Stabilisers	0
13	Instruction Manual & BSEN1004 certificate of conformity	1

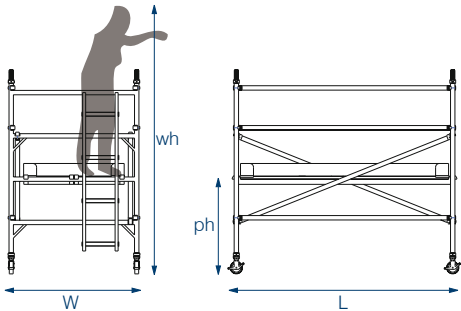
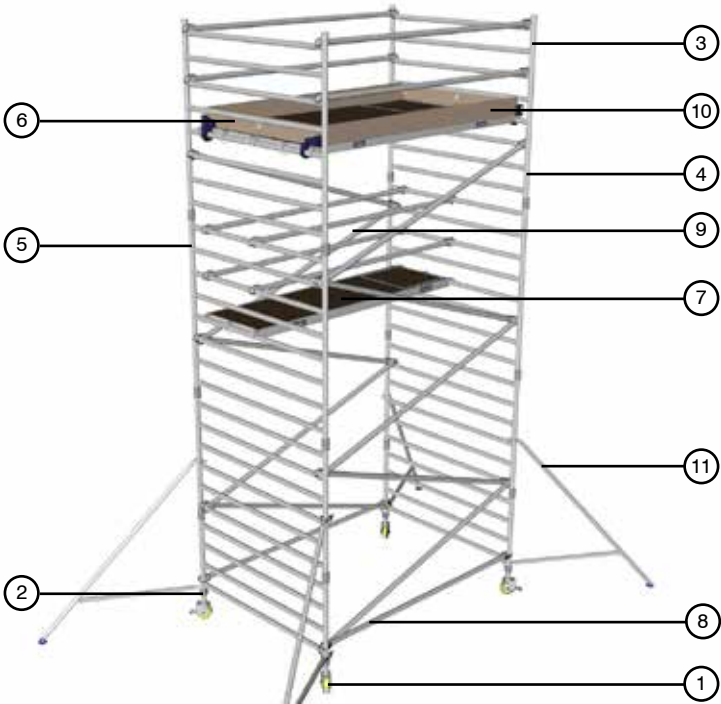

Technical Information

Base Dimensions:	(L)3.2m X (W)1.45m
Maximum Platform Height (ph):	5.7m
Maximum Working Height (wh):	7.7m
Maximum Working Load Per Platform:	275kg
Maximum Working Load Per Tower:	950kg
(including tower weight)	
Weight:	

Double Width Tower
3.2m Long x 1.45m wide

Working Height
8.2m

Platform Height
6.2m

Tower Components

Item	Description	Quantity
1	150mm Locking Castor	4
2	Adjustable Leg 500mm	4
3	4 rung 1m Frame	2
4	6 rung 1.5m Frame	0
5	8 rung 2m Frame	6
6	3.2m Trapdoor Platforms	2
7	3.2m Fixed Platforms	1
8	3.2m Horizontal Brace	10
9	3.5m Diagonal Brace	11
10	Complete Toe Board Set	1
11	Standard Stabilisers	4
12	Jumbo Stabilisers	0
13	Instruction Manual & BSEN1004 certificate of conformity	1

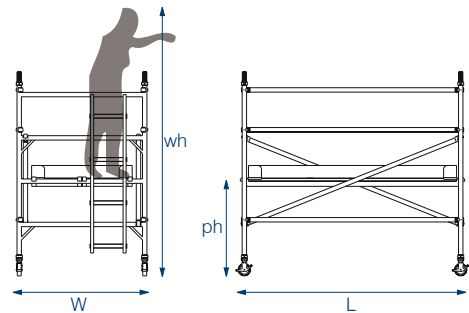
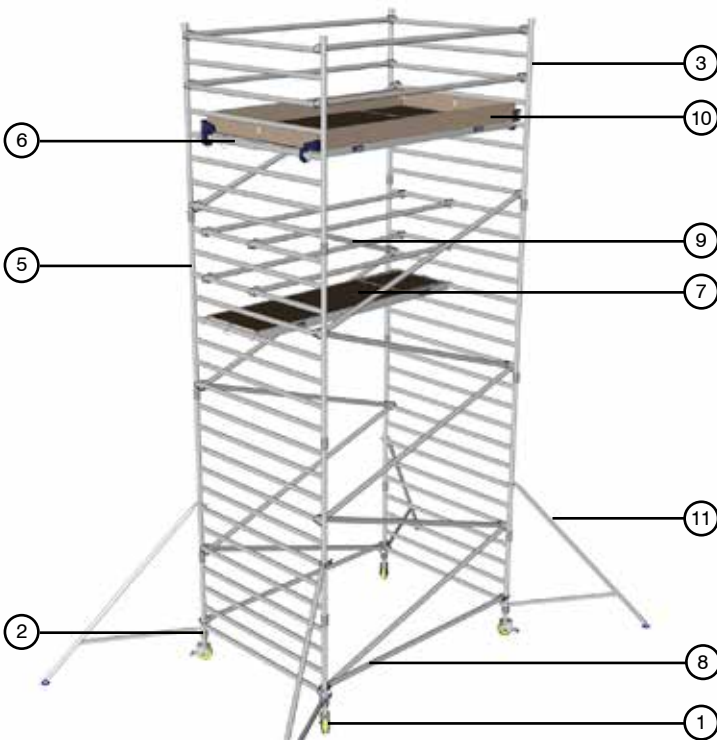

Technical Information

Base Dimensions:	(L)3.2m X (W)1.45m
Maximum Platform Height (ph):	6.2m
Maximum Working Height (wh):	8.2m
Maximum Working Load Per Platform:	275kg
Maximum Working Load Per Tower: (including tower weight)	950kg
Weight:	

Double Width Tower
3.2m Long x 1.45m wide

Working Height
8.7m

Platform Height
6.7m

Tower Components

Item	Description	Quantity
1	150mm Locking Castor	4
2	Adjustable Leg 500mm	4
3	4 rung 1m Frame	0
4	6 rung 1.5m Frame	2
5	8 rung 2m Frame	6
6	3.2m Trapdoor Platforms	3
7	3.2m Fixed Platforms	1
8	3.2m Horizontal Brace	14
9	3.5m Diagonal Brace	12
10	Complete Toe Board Set	1
11	Standard Stabilisers	0
12	Jumbo Stabilisers	4
13	Instruction Manual & BSEN1004 certificate of conformity	1

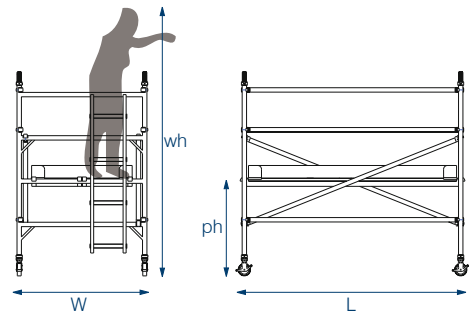
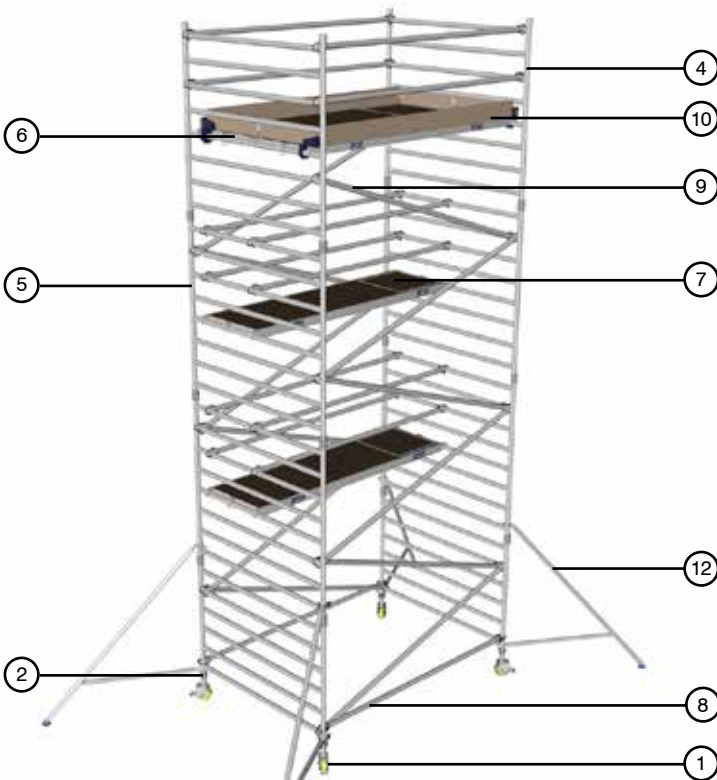

Technical Information

Base Dimensions:	(L)3.2m X (W)1.45m
Maximum Platform Height (ph):	6.7m
Maximum Working Height (wh):	8.7m
Maximum Working Load Per Platform:	275kg
Maximum Working Load Per Tower: (including tower weight)	950kg
Weight:	

Double Width Tower
3.2m Long x 1.45m wide

Working Height
9.2m

Platform Height
7.2m

Tower Components

Item	Description	Quantity
1	150mm Locking Castor	4
2	Adjustable Leg 500mm	4
3	4 rung 1m Frame	0
4	6 rung 1.5m Frame	0
5	8 rung 2m Frame	8
6	3.2m Trapdoor Platforms	3
7	3.2m Fixed Platforms	1
8	3.2m Horizontal Brace	14
9	3.5m Diagonal Brace	13
10	Complete Toe Board Set	1
11	Standard Stabilisers	0
12	Jumbo Stabilisers	4
13	Instruction Manual & BSEN1004 certificate of conformity	1

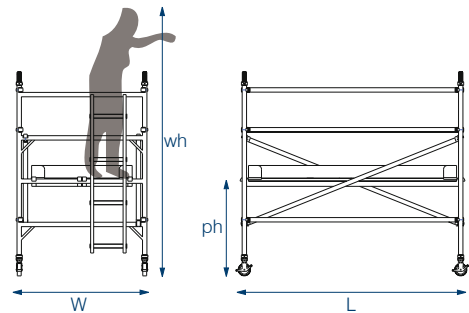
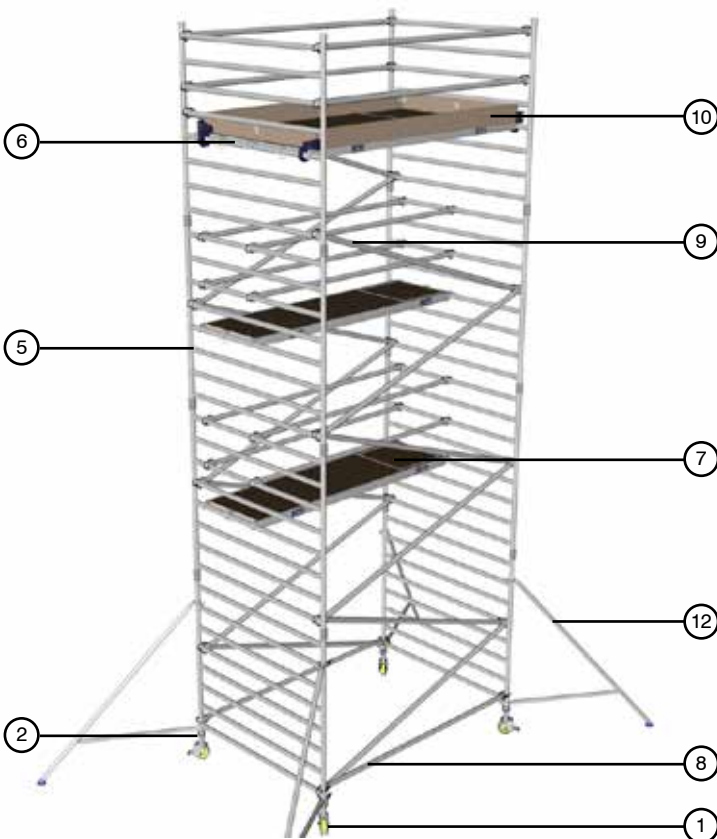

Technical Information

Base Dimensions:	(L)3.2m X (W)1.45m
Maximum Platform Height (ph):	7.2m
Maximum Working Height (wh):	9.2m
Maximum Working Load Per Platform:	275kg
Maximum Working Load Per Tower:	950kg
(including tower weight)	
Weight:	

Double Width Tower
3.2m Long x 1.45m wide

Working Height
9.7m

Platform Height
7.7m

Tower Components

Item	Description	Quantity
1	150mm Locking Castor	4
2	Adjustable Leg 500mm	4
3	4 rung 1m Frame	2
4	6 rung 1.5m Frame	2
5	8 rung 2m Frame	6
6	3.2m Trapdoor Platforms	3
7	3.2m Fixed Platforms	1
8	3.2m Horizontal Brace	14
9	3.5m Diagonal Brace	14
10	Complete Toe Board Set	1
11	Standard Stabilisers	0
12	Jumbo Stabilisers	4
13	Instruction Manual & BSEN1004 certificate of conformity	1

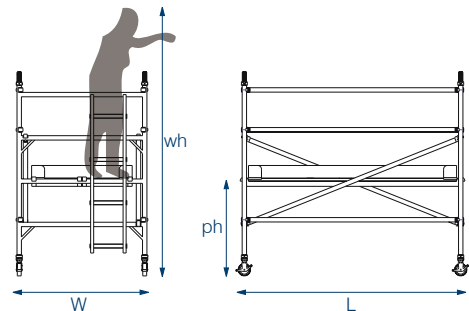
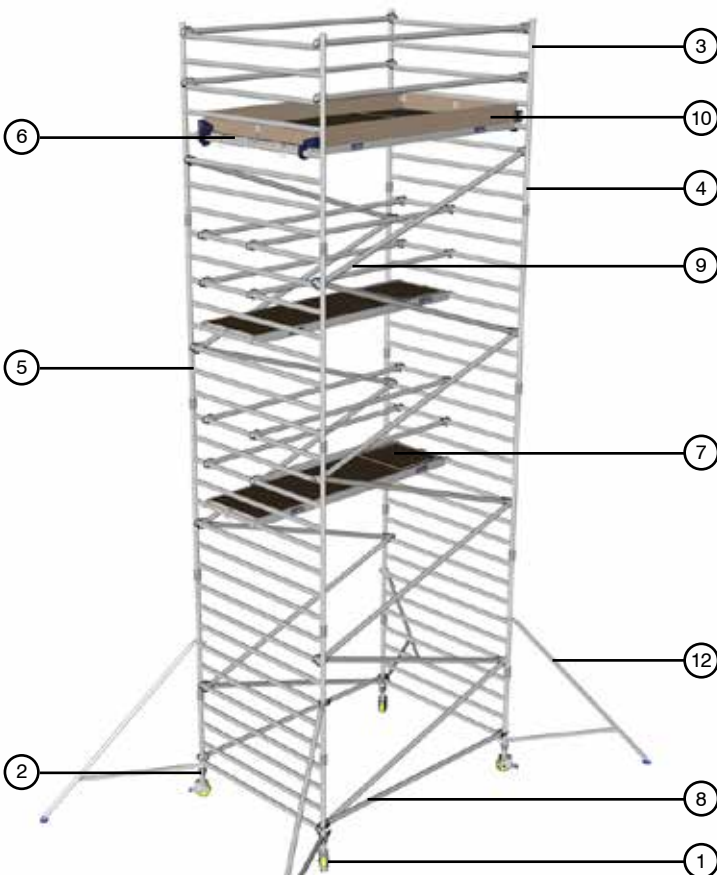

Technical Information

Base Dimensions:	(L)3.2m X (W)1.45m
Maximum Platform Height (ph):	7.7m
Maximum Working Height (wh):	9.7m
Maximum Working Load Per Platform:	275kg
Maximum Working Load Per Tower: (including tower weight)	950kg
Weight:	

Double Width Tower
3.2m Long x 1.45m wide

Working Height
10.2m

Platform Height
8.2m

Tower Components

Item	Description	Quantity
1	150mm Locking Castor	4
2	Adjustable Leg 500mm	4
3	4 rung 1m Frame	2
4	6 rung 1.5m Frame	0
5	8 rung 2m Frame	8
6	3.2m Trapdoor Platforms	3
7	3.2m Fixed Platforms	1
8	3.2m Horizontal Brace	14
9	3.5m Diagonal Brace	15
10	Complete Toe Board Set	1
11	Standard Stabilisers	0
12	Jumbo Stabilisers	4
13	Instruction Manual & BSEN1004 certificate of conformity	1

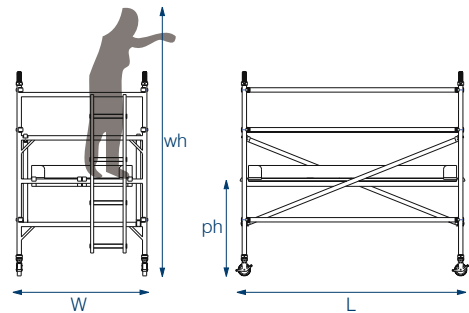
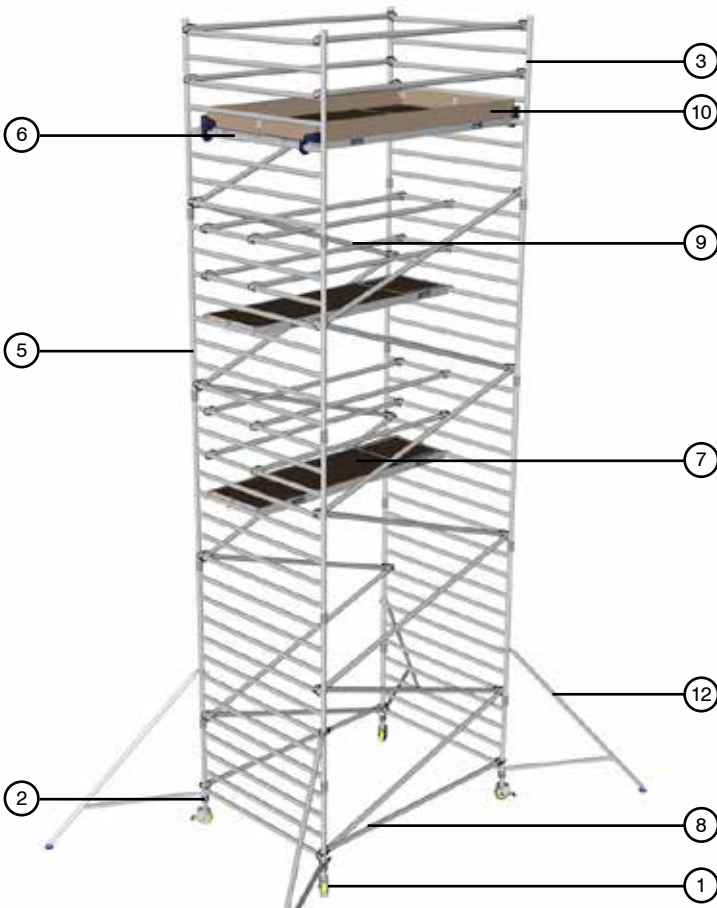

Technical Information

Base Dimensions:	(L)3.2m X (W)1.45m
Maximum Platform Height (ph):	8.2m
Maximum Working Height (wh):	10.2m
Maximum Working Load Per Platform:	275kg
Maximum Working Load Per Tower: (including tower weight)	950kg
Weight:	

Double Width Tower
3.2m Long x 1.45m wide

Working Height
10.7m

Platform Height
8.7m

Tower Components

Item	Description	Quantity
1	150mm Locking Castor	4
2	Adjustable Leg 500mm	4
3	4 rung 1m Frame	0
4	6 rung 1.5m Frame	2
5	8 rung 2m Frame	8
6	3.2m Trapdoor Platforms	3
7	3.2m Fixed Platforms	1
8	3.2m Horizontal Brace	14
9	3.5m Diagonal Brace	16
10	Complete Toe Board Set	1
11	Standard Stabilisers	0
12	Jumbo Stabilisers	4
13	Instruction Manual & BSEN1004 certificate of conformity	1

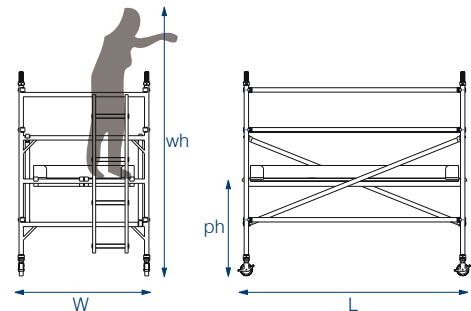
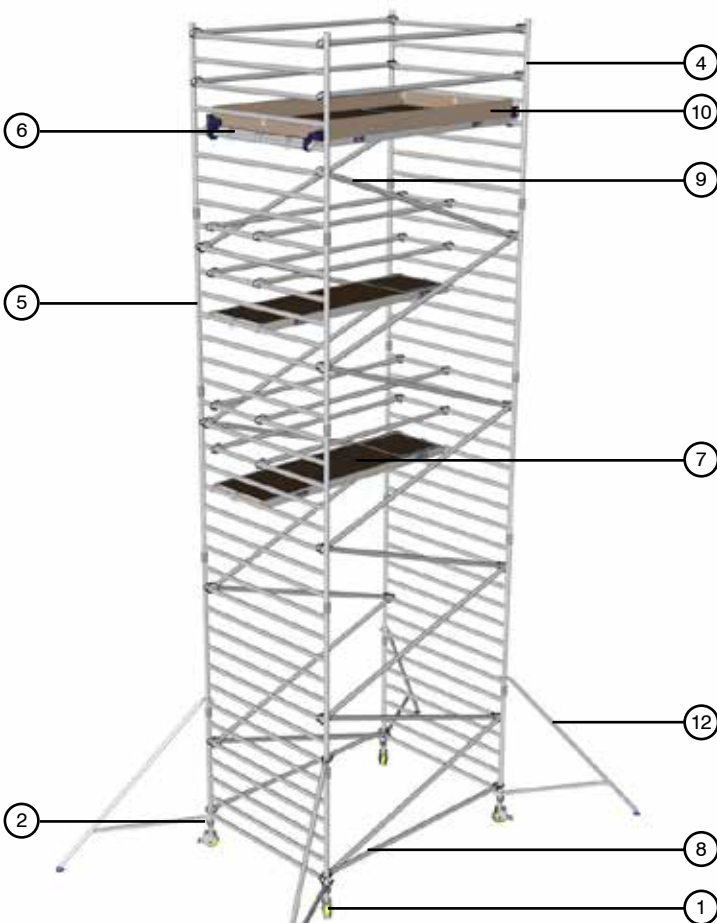

Technical Information

Base Dimensions:	(L)3.2m X (W)1.45m
Maximum Platform Height (ph):	8.7m
Maximum Working Height (wh):	10.7m
Maximum Working Load Per Platform:	275kg
Maximum Working Load Per Tower: (including tower weight)	950kg
Weight:	

Double Width Tower
3.2m Long x 1.45m wide

Working Height
11.2m

Platform Height
9.2m

Tower Components

Item	Description	Quantity
1	150mm Locking Castor	4
2	Adjustable Leg 500mm	4
3	4 rung 1m Frame	0
4	6 rung 1.5m Frame	0
5	8 rung 2m Frame	10
6	3.2m Trapdoor Platforms	3
7	3.2m Fixed Platforms	1
8	3.2m Horizontal Brace	14
9	3.5m Diagonal Brace	17
10	Complete Toe Board Set	1
11	Standard Stabilisers	0
12	Jumbo Stabilisers	4
13	Instruction Manual & BSEN1004 certificate of conformity	1

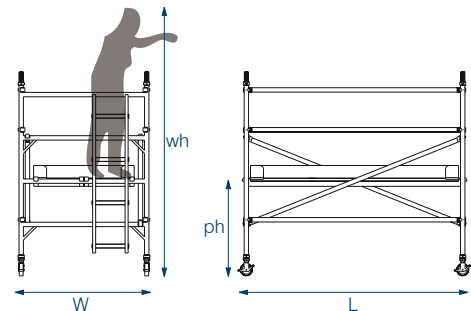
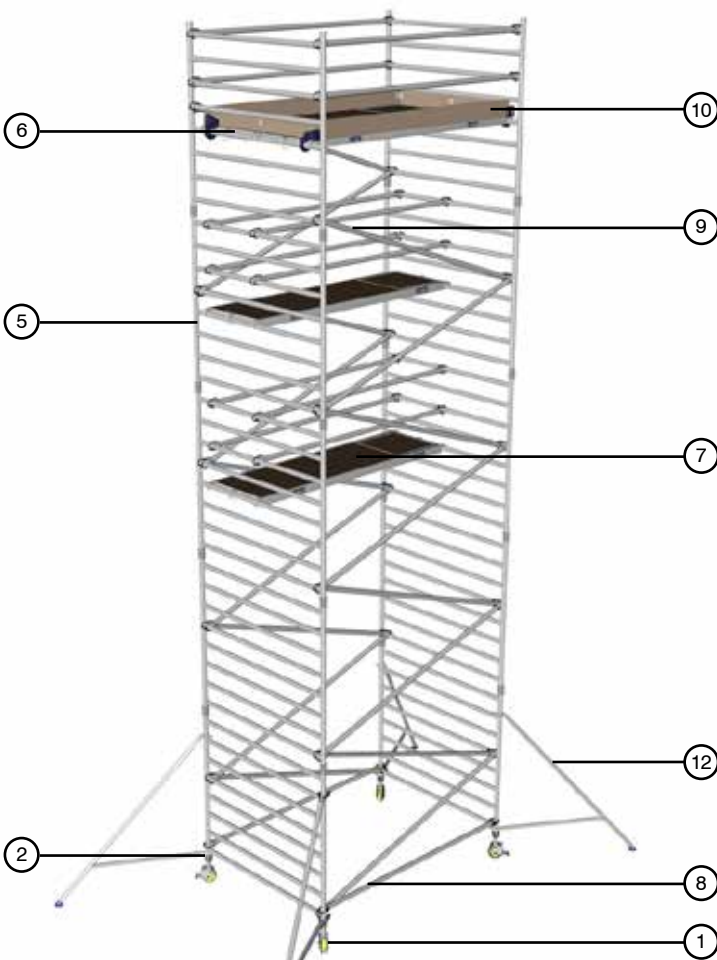

Technical Information

Base Dimensions:	(L)3.2m X (W)1.45m
Maximum Platform Height (ph):	9.2m
Maximum Working Height (wh):	11.2m
Maximum Working Load Per Platform:	275kg
Maximum Working Load Per Tower: (including tower weight)	950kg
Weight:	

Double Width Tower
3.2m Long x 1.45m wide

Working Height
11.7m

Platform Height
9.7m

Tower Components

Item	Description	Quantity
1	150mm Locking Castor	4
2	Adjustable Leg 500mm	4
3	4 rung 1m Frame	2
4	6 rung 1.5m Frame	2
5	8 rung 2m Frame	8
6	3.2m Trapdoor Platforms	3
7	3.2m Fixed Platforms	1
8	3.2m Horizontal Brace	14
9	3.5m Diagonal Brace	18
10	Complete Toe Board Set	1
11	Standard Stabilisers	0
12	Jumbo Stabilisers	4
13	Instruction Manual & BSEN1004 certificate of conformity	1

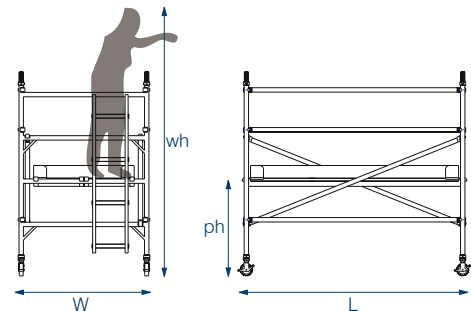
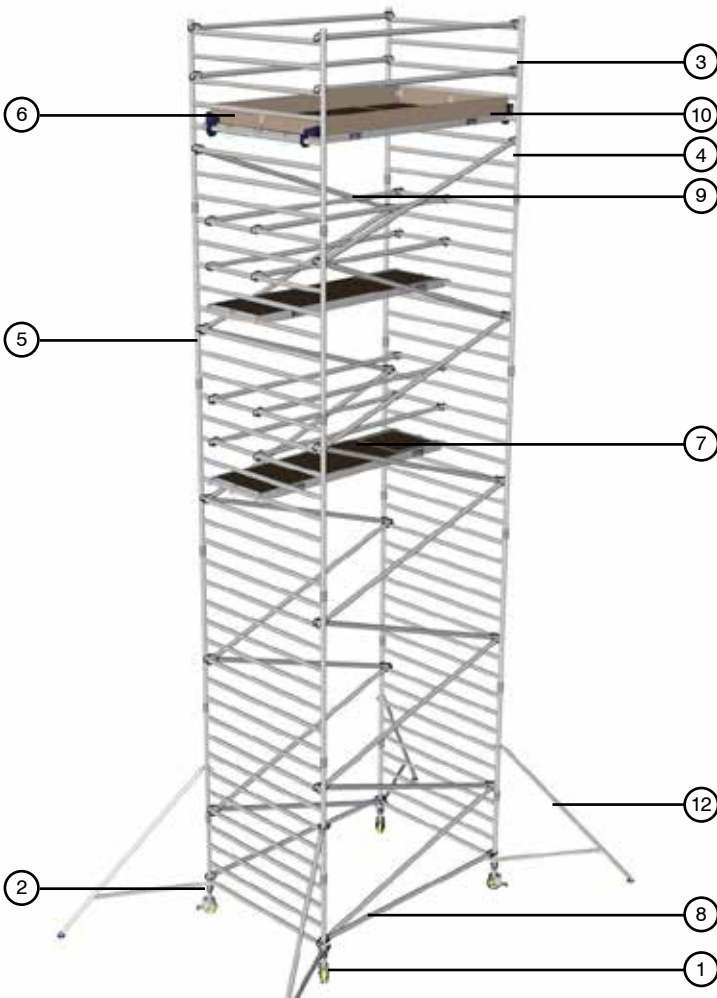

Technical Information

Base Dimensions:	(L)3.2m X (W)1.45m
Maximum Platform Height (ph):	9.7m
Maximum Working Height (wh):	11.7m
Maximum Working Load Per Platform:	275kg
Maximum Working Load Per Tower: (including tower weight)	950kg
Weight:	

Double Width Tower
3.2m Long x 1.45m wide

Working Height
12.2m

Platform Height
10.2m

Tower Components

Item	Description	Quantity
1	150mm Locking Castor	4
2	Adjustable Leg 500mm	4
3	4 rung 1m Frame	2
4	6 rung 1.5m Frame	0
5	8 rung 2m Frame	10
6	3.2m Trapdoor Platforms	3
7	3.2m Fixed Platforms	1
8	3.2m Horizontal Brace	14
9	3.5m Diagonal Brace	19
10	Complete Toe Board Set	1
11	Standard Stabilisers	0
12	Jumbo Stabilisers	4
13	Instruction Manual & BSEN1004 certificate of conformity	1

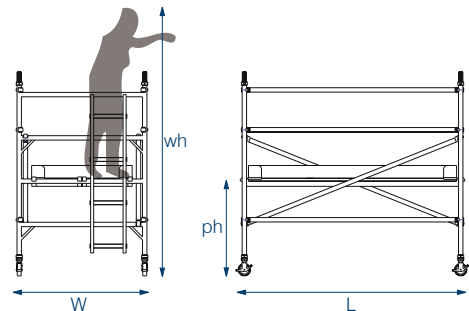
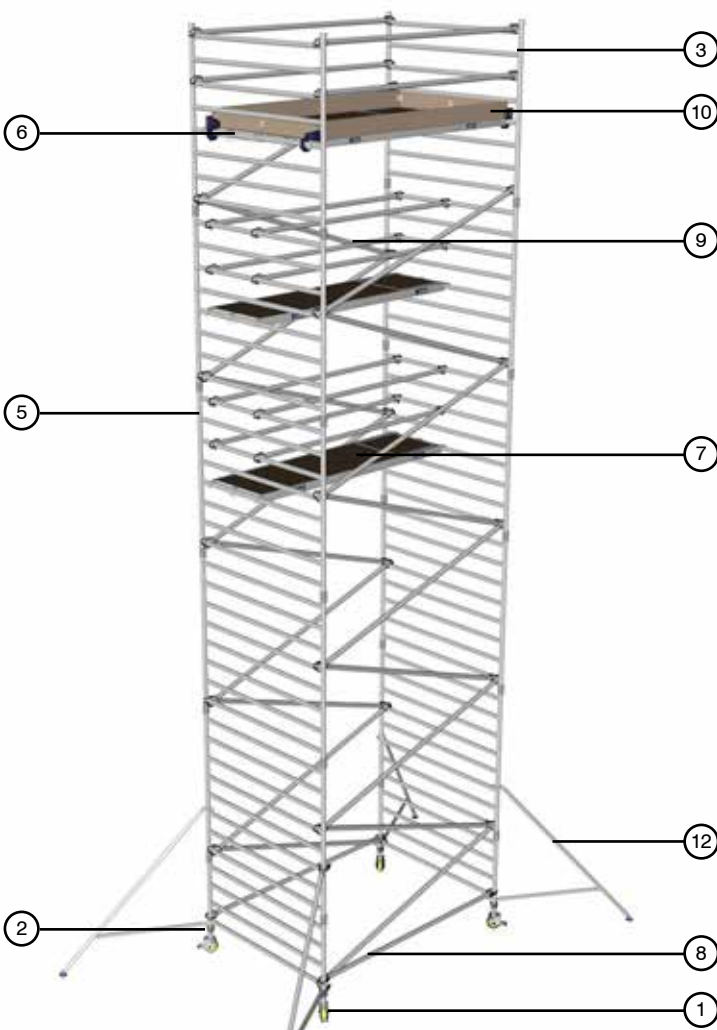

Technical Information

Base Dimensions:	(L)3.2m X (W)1.45m
Maximum Platform Height (ph):	10.2m
Maximum Working Height (wh):	12.2m
Maximum Working Load Per Platform:	275kg
Maximum Working Load Per Tower: (including tower weight)	950kg
Weight:	

Double Width Tower
3.2m Long x 1.45m wide

Working Height
12.7m

Platform Height
10.7m

Tower Components

Item	Description	Quantity
1	150mm Locking Castor	4
2	Adjustable Leg 500mm	4
3	4 rung 1m Frame	0
4	6 rung 1.5m Frame	2
5	8 rung 2m Frame	10
6	3.2m Trapdoor Platforms	4
7	3.2m Fixed Platforms	1
8	3.2m Horizontal Brace	16
9	3.5m Diagonal Brace	20
10	Complete Toe Board Set	1
11	Standard Stabilisers	0
12	Jumbo Stabilisers	4
13	Instruction Manual & BSEN1004 certificate of conformity	1

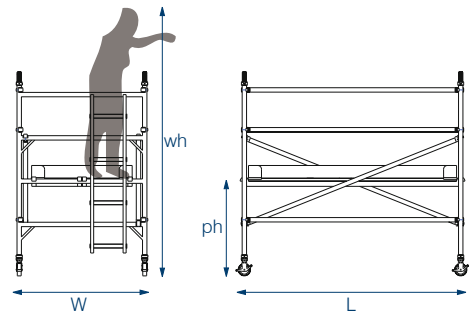
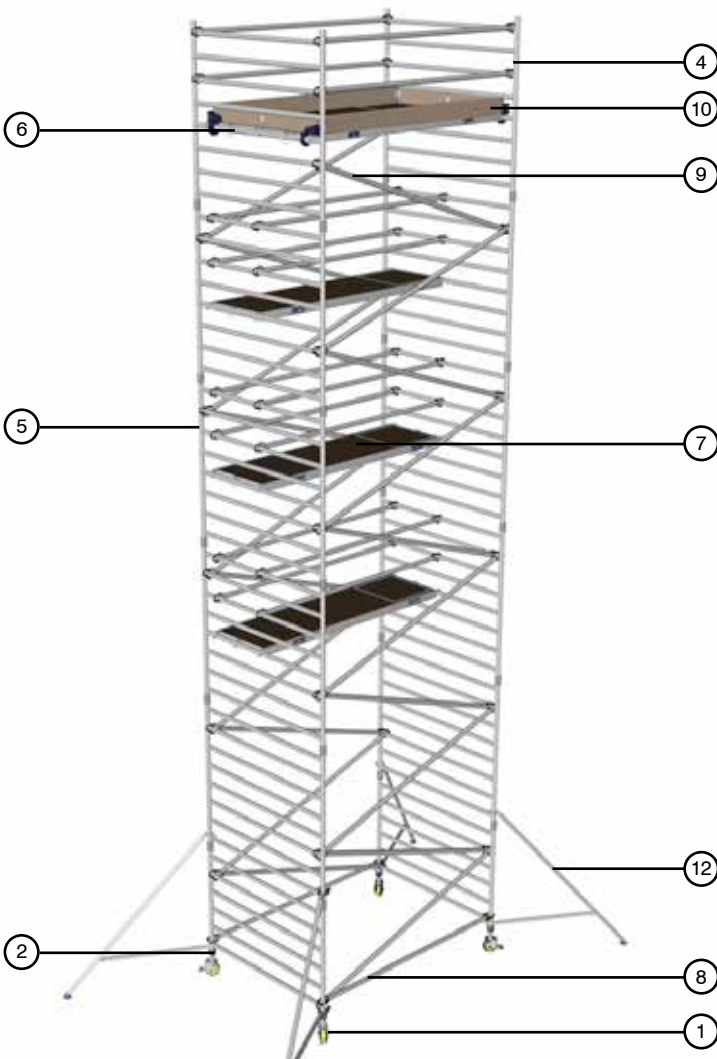

Technical Information

Base Dimensions:	(L)3.2m X (W)1.45m
Maximum Platform Height (ph):	10.7m
Maximum Working Height (wh):	12.7m
Maximum Working Load Per Platform:	275kg
Maximum Working Load Per Tower: (including tower weight)	950kg
Weight:	

Double Width Tower
3.2m Long x 1.45m wide

Working Height
13.2m

Platform Height
11.2m

Tower Components

Item	Description	Quantity
1	150mm Locking Castor	4
2	Adjustable Leg 500mm	4
3	4 rung 1m Frame	0
4	6 rung 1.5m Frame	0
5	8 rung 2m Frame	12
6	3.2m Trapdoor Platforms	4
7	3.2m Fixed Platforms	1
8	3.2m Horizontal Brace	18
9	3.5m Diagonal Brace	21
10	Complete Toe Board Set	1
11	Standard Stabilisers	0
12	Jumbo Stabilisers	4
13	Instruction Manual & BSEN1004 certificate of conformity	1

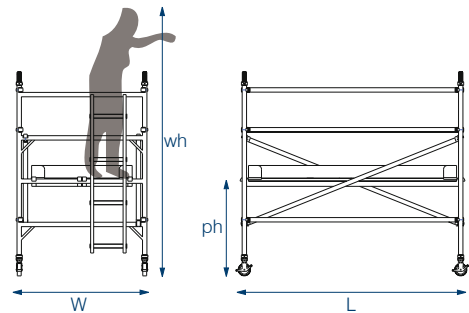
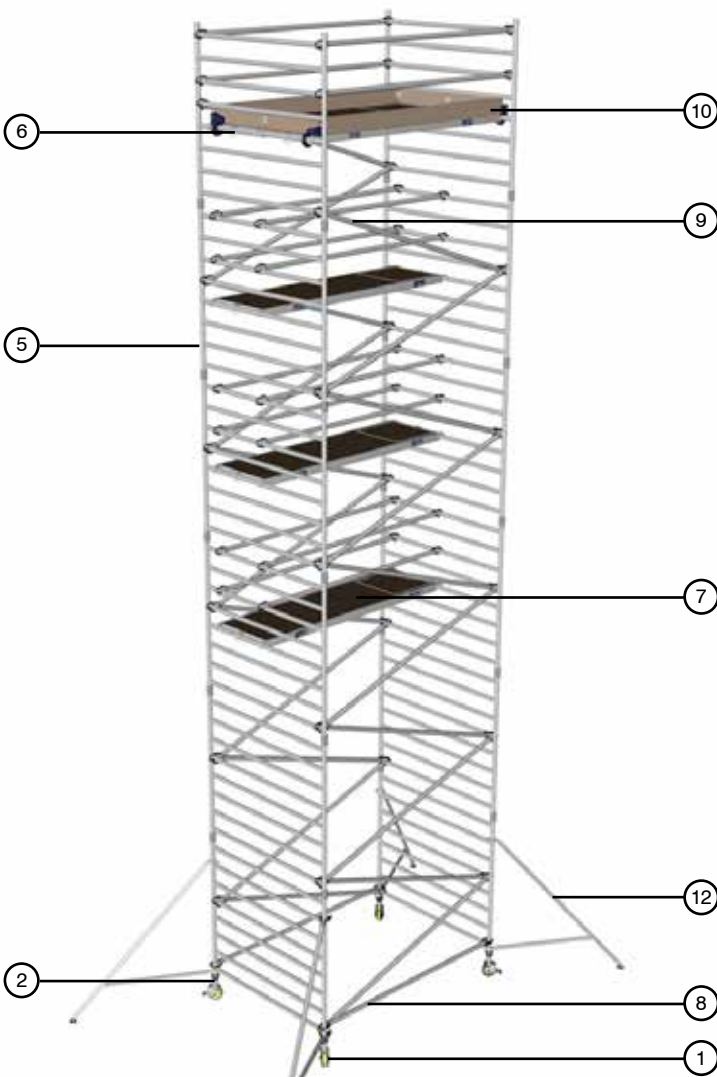

Technical Information

Base Dimensions:	(L)3.2m X (W)1.45m
Maximum Platform Height (ph):	11.2m
Maximum Working Height (wh):	13.2m
Maximum Working Load Per Platform:	275kg
Maximum Working Load Per Tower: (including tower weight)	950kg
Weight:	

Double Width Tower
3.2m Long x 1.45m wide

Working Height
13.7m

Platform Height
11.7m

Tower Components

Item	Description	Quantity
1	150mm Locking Castor	4
2	Adjustable Leg 500mm	4
3	4 rung 1m Frame	2
4	6 rung 1.5m Frame	2
5	8 rung 2m Frame	10
6	3.2m Trapdoor Platforms	4
7	3.2m Fixed Platforms	1
8	3.2m Horizontal Brace	18
9	3.5m Diagonal Brace	22
10	Complete Toe Board Set	1
11	Standard Stabilisers	0
12	Jumbo Stabilisers	4
13	Instruction Manual & BSEN1004 certificate of conformity	1

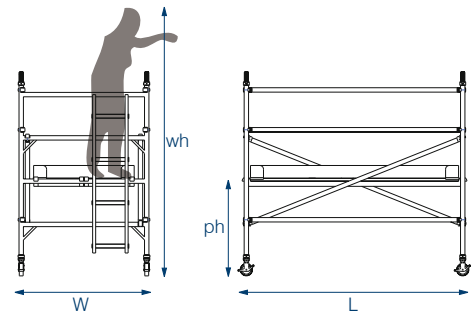
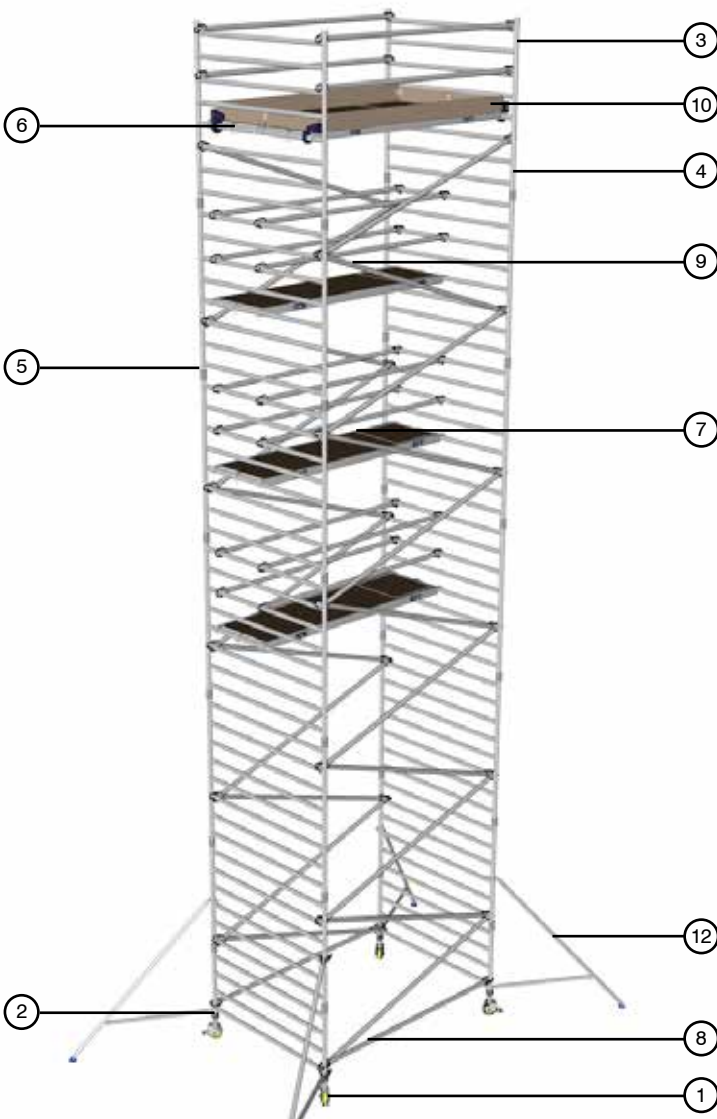

Technical Information

Base Dimensions:	(L)3.2m X (W)1.45m
Maximum Platform Height (ph):	11.7m
Maximum Working Height (wh):	13.7m
Maximum Working Load Per Platform:	275kg
Maximum Working Load Per Tower: (including tower weight)	950kg
Weight:	

Double Width Tower
3.2m Long x 1.45m wide

Working Height
14.2m

Platform Height
12.2m

Tower Components

Item	Description	Quantity
1	150mm Locking Castor	4
2	Adjustable Leg 500mm	4
3	4 rung 1m Frame	2
4	6 rung 1.5m Frame	0
5	8 rung 2m Frame	12
6	3.2m Trapdoor Platforms	4
7	3.2m Fixed Platforms	1
8	3.2m Horizontal Brace	18
9	3.5m Diagonal Brace	23
10	Complete Toe Board Set	1
11	Standard Stabilisers	0
12	Jumbo Stabilisers	4
13	Instruction Manual & BSEN1004 certificate of conformity	1

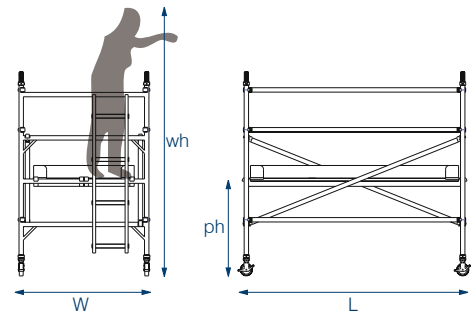
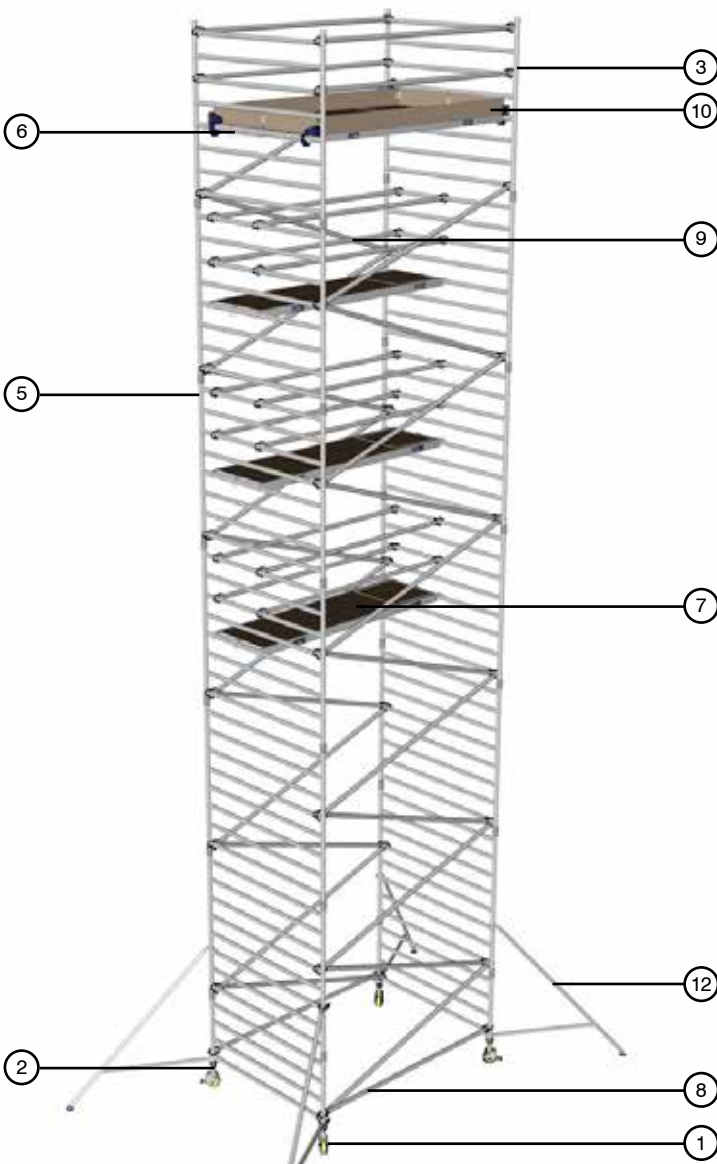

Technical Information

Base Dimensions:	(L)3.2m X (W)1.45m
Maximum Platform Height (ph):	12.2m
Maximum Working Height (wh):	14.2m
Maximum Working Load Per Platform:	275kg
Maximum Working Load Per Tower: (including tower weight)	950kg
Weight:	